

Clarke®



PROPANE GAS HEATER

MODEL NO: DEVIL 4000

PART NO: 6926150

OPERATION & MAINTENANCE INSTRUCTIONS

UK
CA | CE



ORIGINAL INSTRUCTIONS

DL1123- Rev 7

INTRODUCTION

Thank you for purchasing this CLARKE product. Before attempting to use this product, please read this manual thoroughly and follow the instructions carefully.

GUARANTEE

This product is guaranteed against faulty manufacture for a period of 12 months from the date of purchase. Please keep your receipt which will be required as proof of purchase. This guarantee is invalid if the product is found to have been abused or tampered with in any way, or not used for the purpose for which it was intended.

Faulty goods should be returned to their place of purchase, no product can be returned to us without prior permission.

This guarantee does not effect your statutory rights.

FUNCTION AND OPERATING PARAMETERS

This is a forced air heater meaning that a blower or fan pushes the air through the heater. Proper combustion depends upon the air flow.

Therefore, the heater must not be modified or operated with parts removed or missing. Likewise, safety systems must not be circumvented or modified in order to operate the heater.

This heater is intended for drying and the warming of commercial/industrial buildings where adequate ventilation is provided.

This heater is not intended;

- It must be operated as prescribed in the operating manual.
- It is not intended to be used for domestic use or for the heating of habitable areas.
- It is not intended to be used to reach and maintain a certain level of human thermal comfort within an enclosed space in which the heater is situated.
- It is not intended to be used in enclosed areas with restricted ventilation.
- It is not for use in areas with high levels of fluctuating drafts.
- **DO NOT** use for warming animals or live stock.

SAFETY INFORMATION

Read, and make sure you fully understand the following precautions and the hazards associated with this type of equipment.

1. **ONLY** use with the voltage specified and ensure the heater is properly earthed.
2. Use only the hose and factory preset regulator provided with the heater.
3. **ONLY** use propane gas, set up for vapour withdrawal.
4. Use only in well ventilated areas. Provide ventilation of at least 3 square feet of fresh air for every 100,000 BTU/hr of rating.
5. **DO NOT** use this heater in small rooms when they are occupied by persons not capable of leaving the room on their own unless constant supervision is provided.
6. For indoor use only. **DO NOT** use heater outdoors.
7. **DO NOT** use this heater in the immediate surrounds of a bath, a shower or a swimming pool
8. **DO NOT** use this heater in small rooms when they are occupied by persons not capable of leaving the room on their own unless constant supervision is provided.
9. **DO NOT** use for the heating of habitable areas of domestic premises; for use in public buildings, refer to national regulations.
10. **DO NOT** use the heater in a basement or below ground level. Propane gas is heavier than air. If a leak occurs. propane gas will sink to the lowest possible level.
11. Keep the heater area clear and free from combustible materials, gasoline, paint thinner and other flammable vapours and liquids. Leave a minimum of 6ft (1.83m) clearances in all directions
12. **DO NOT** use heater in areas with high dust content. Dust is combustible.
13. **DO NOT** point the heater at the propane tank.
14. Keep propane tank(s) below 100°F (37.8°C).
15. Check the heater for damage before each use. **DO NOT** use if dropped. **DO NOT** use a damaged heater.
16. Check the hose before each use of the heater. If highly worn or cut, replace with hose specified by the manufacturer before using the heater.
17. Locate the heater on a stable and level surface if the heater is hot or operating.
18. Not intended for use on finished floors.
19. **NEVER** block the air inlet (rear) or air outlet (front) of the heater.

20. Keep the heater away from strong drafts, water spray, rain or dripping water.
21. **DO NOT** leave the heater unattended.
22. **NEVER** move, handle or service a hot, operating or plugged-in heater.
23. To prevent injury wear gloves when handling the heater.
24. **NEVER** attach duct work to front or rear of the heater.
25. **DO NOT** alter the heater. Keep the heater in its original state.
26. Turn off the propane supply and unplug the heater when not in use.
27. Use only original replacement parts. This heater must use design-specific parts. Improper replacement parts could be highly dangerous.
28. **DO NOT** place torsional stress on any hoses or cables.
29. **DO NOT** use this heater with a programmer, timer, separate remote control system or any other device that switches the heater on automatically, since a fire risk exists if the heater is covered or positioned incorrectly.
30. This heater is only intended for use in industrial, commercial and building industries, it is **NOT** to be used by children or persons with reduced physical, sensory or mental capabilities, or lack of experience and knowledge.
31. Keep all children and animals away from the heater.
32. **DO NOT** use for warming animals or live stock.
33. Children should **NOT** play with the appliance.

SAFETY SYMBOLS

Please read all of the safety and operating instructions carefully before using this product. The following safety symbols may be found on the product.

	<p>GENERAL HAZARD WARNING</p>		<p>HOT SURFACE, DO NOT TOUCH</p>
	<p>ALWAYS READ THIS MANUAL BEFORE USE</p>	 <p>DO NOT COVER</p>	<p>DO NOT COVER</p>

GENERAL PRECAUTIONS

Even though this heater operates very close to 100 percent combustion efficiency, it still produces small amounts of carbon monoxide.

- Carbon Monoxide (CO) is toxic.
- Pregnant women, persons with a heart or lung condition, anaemia or under the influence of alcohol, or those at high altitude, are more likely to be effected by Carbon Monoxide.
- CO can build up in a confined space and failure to provide adequate ventilation can be fatal.

The early symptoms of asphyxiation caused by inadequate ventilation are:

- headache
- dizziness
- nausea
- dry mouth or sore throat

Should anyone show these symptoms, they must **GET FRESH AIR IMMEDIATELY**. Turn off the heater and have it serviced before using again.

Be sure to follow all warnings in this manual.

WE RECOMMEND THE USE OF A CARBON MONOXIDE DETECTOR

BYSTANDERS

When the heater is to be operated in the presence of other people the user is responsible for informing those present of the safety precautions and of the hazards involved.

ENVIRONMENTAL RECYCLING POLICY



Through purchase of this product, the customer is taking on the obligation to deal with the WEEE in accordance with the WEEE regulations in relation to the treatment, recycling & recovery and environmentally sound disposal of the WEEE.

In effect, this means that this product must not be disposed of with general household waste. It must be disposed of according to the laws governing Waste Electrical and Electronic Equipment (WEEE) at a recognised disposal facility.

ELECTRICAL CONNECTIONS



WARNING: READ THESE ELECTRICAL SAFETY INSTRUCTIONS THOROUGHLY BEFORE CONNECTING THE PRODUCT TO THE MAINS SUPPLY.

Connect the mains lead to a standard, 230 Volt (50Hz) electrical supply through an approved BS1363 plug fitted with a BS1362 13 amp fuse.

If the plug has to be changed because of damage, it must be removed and a replacement fitted, following the wiring instructions shown below. The old plug must be discarded safely, as insertion into a power socket could cause an electrical hazard.



WARNING: WIRES IN THE MAINS LEAD ARE COLOURED IN ACCORDANCE WITH THE FOLLOWING CODE: GREEN/YELLOW = EARTH, BLUE = NEUTRAL, BROWN = LIVE.

- The BLUE wire must be connected to the terminal marked N or coloured black.
- The BROWN wire must be connected to the terminal marked L or coloured red.
- The YELLOW AND GREEN wire must be connected to the terminal marked E or \perp or coloured green.

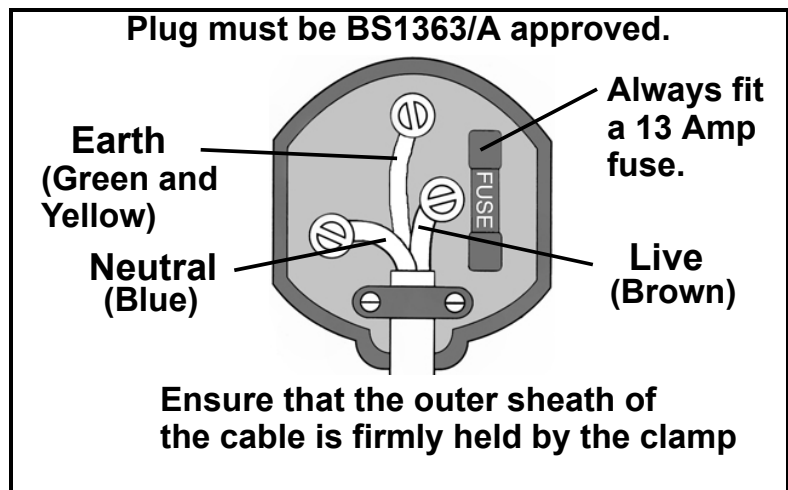

We strongly recommend that this machine is connected to the mains supply through a Residual Current Device (RCD)

If you are not sure, consult a qualified electrician. DO NOT try to do any repairs.

PROPANE GAS SUPPLY



WARNING: THE FITTING AND CHANGING OF THE GAS CYLINDERS MUST BE CARRIED OUT IN A FLAME FREE ATMOSPHERE.

WARNING: YOU SHOULD ONLY USE PROPANE GAS CYLINDERS AVAILABLE FROM BUILDERS MERCHANTS OR GAS SUPPLIERS.

This portable, direct-fired gas heater is designed to give safe, efficient and reliable operation, and is for use with propane gas only.

As with all mechanical equipment, optimum performance will only be achieved if the correct operation and servicing procedures are followed.



WARNING: PROPANE GAS CYLINDERS MUST BE USED AND STORED IN ACCORDANCE WITH THE 'HIGHLY FLAMMABLE LIQUIDS AND LIQUEFIED PETROLEUM GASES REGULATIONS 1972'

In order to reduce the risk of icing up when operating at long periods at maximum capacity, you should use a larger capacity gas bottle, or two/ three bottles in parallel as shown in the diagram.

Ensure the Propane gas bottle, gas hose and electric cable, are positioned behind the unit, away from the heat.

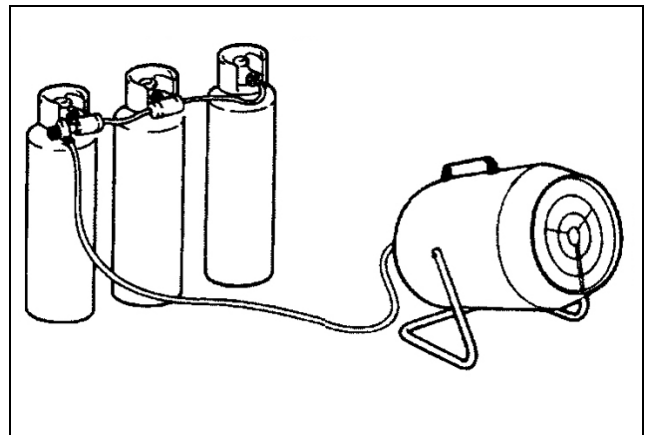

IN THE EVENT OF A GAS LEAK

1. Extinguish all smoking materials and other open flames.
2. Do NOT operate electric switches or light matches.
3. Close all supply valves on gas tank or cylinder.
4. Do NOT use your phone. USE a neighbour's phone or your mobile phone from outside the building or wherever you detected the gas leak to call the fire service.
5. Immediately get everyone out of the building or area.

Do NOT re-enter the building, or area until a trained service person or the fire service advises it is safe to return.

ASSEMBLY

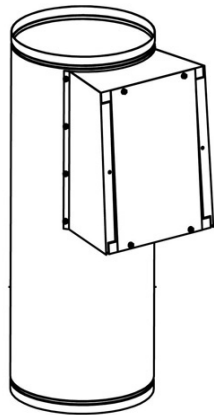

1. Stand the heater on end as shown. **We recommend the help of an assistant to lift and steady the heater during assembly.**

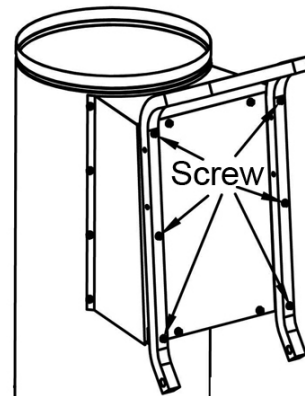

2. Attach the lower frame and secure using six of the machine screws provided.

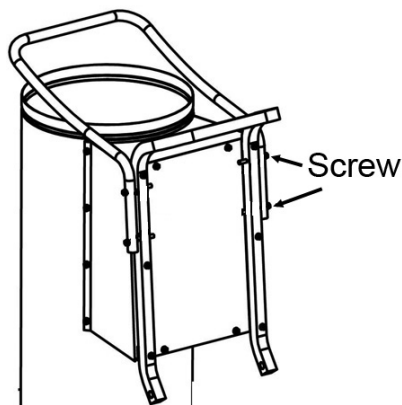

3. Attach the handle to the lower frame and secure using four machine screws.

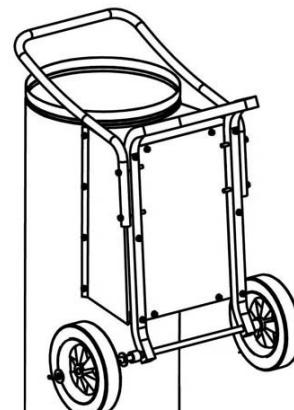

4. Slide the axle into position.
5. Place the axle sleeve onto each end.
6. Place the wheels onto each end.
7. Place the spacer onto each end.
8. Secure everything in place with a cotter pin on each end of the axle.

PREPARATION

LOCATION

- Position the heater at a safe distance from combustible materials.
- This heater must not be placed on wooden floors or other combustible materials.
- When used, the heater should rest on suitable insulating material at least 1 inch thick and extending 3 ft or more beyond the heater in all directions.

SIZE AND CAPACITY OF PROPANE CYLINDERS

The chart shows the approximate size of the cylinder required for these heaters. To use the chart:

1. Select the lowest air temperature expected (at the bottom of the chart).
2. Move straight up to time of operation desired (left side).
3. Read the cylinder size required

Always use full cylinders with good air circulation and no frost on the cylinders.

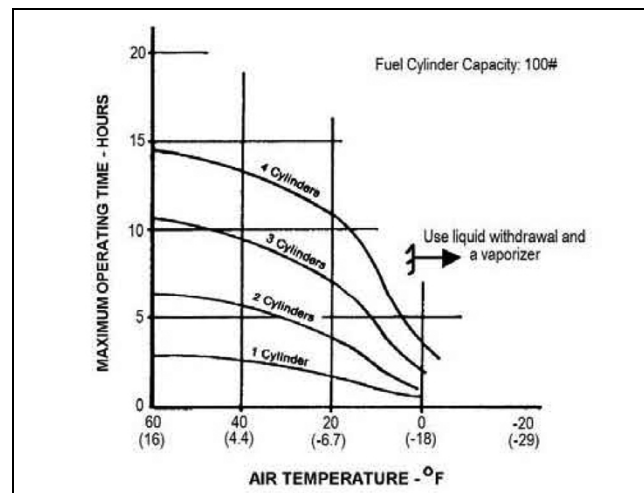

CONNECTING THE GAS BOTTLE

1. Check the heater for possible shipping damage. If any is found do not use the heater.
2. Follow all of the "General Safety" precautions on page 3.
3. Connect a POL (Prest-o-Lite) fitting on hose/regulator assembly to the propane tank(s).
 - Turn the POL fitting anti-clockwise into the threads on the tank. Tighten firmly using a wrench.
4. Connect the hose to the heater by rotating the hose fitting clockwise.
 - Make sure that all gas connections are secure.
5. Open the cylinder's gas valve and check all gas connections with a soap and water solution. DO NOT USE A FLAME.
6. Connect the power cable to a 230V, 50Hz, mains socket.

OPERATING INSTRUCTIONS



WARNING: BEFORE STARTING THE HEATER, YOU MUST ENSURE THAT THE MINIMUM VENTILATION REQUIREMENTS ARE OBSERVED TO AVOID THE RISK OF CARBON MONOXIDE POISONING.

HEATER START UP

1. Open the propane supply valve on the propane tank(s) slowly.
 - If not opened slowly, the excess-flow check valve on the propane tank will stop the gas flow. If this happens, close the propane supply valve and open again slowly.
2. Set thermostat to 'high'.
 - The heater will ignite automatically.
3. Adjust the heat output to the desired setting.
4. Set the thermostat to the required setting.
 - The heater will turn off and on automatically as the air temperature varies in the heater area.

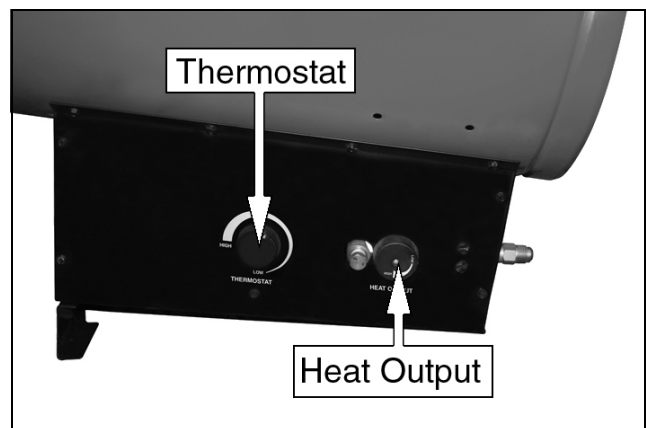

HEATER SHUT DOWN

1. Securely close the valve on the propane cylinder.
2. Continue to operate the heater until all fuel in the hose has burned.
3. Set the power switch to the OFF (O) position.
4. Turn the heater thermostat to "off".
5. Unplug the heater.

RESTART AFTER SAFETY SHUTDOWN

1. Securely close the valve on the propane cylinder.
2. Unplug heater.
3. Wait 5 minutes.
4. Restart, following the Heater Start Up procedure above.

MAINTENANCE, STORAGE AND SERVICING



WARNING: TO PREVENT PERSONAL INJURY, UNPLUG THE HEATER FROM THE MAINS SUPPLY BEFORE SERVICING.

MAINTENANCE AND STORAGE

1. The heater should be inspected at least annually by a qualified person.
2. Before each use, check the soft “O” ring seat at the bullnose of the POL fitting. If the “O” ring is cut, scuffed, or otherwise damaged, replace it.
3. Turn off the gas at the LP-gas supply cylinder(s) when the heater is not in use.
4. When the heater is to be stored indoors, the connection between the LP-gas supply cylinder(s) and the heater must be disconnected and the cylinder(s) removed from the heater and stored out of doors in accordance with local regulations.

SERVICING

A hazardous condition may result if a heater is used that has been modified or is not functioning properly. When the heater is working properly:

- The flame is contained within the heater.
- The flame is essentially blue with perhaps some yellow tipping.
- There is no strong disagreeable odour, eye burning or other physical discomfort.
- There is no smoke or soot internal or external to the heater.
- There are no unplanned or unexplained shut downs of the heater.

The parts lists and wiring diagram show the heater as it was constructed. Do not use a heater which is different from that shown. In this regard, use only the hose, regulator and cylinder connection fitting (POL fitting) supplied with the heater.

A heater which is not working correctly must be repaired, but only by a trained, experienced service person.

SPECIFICATIONS

Model	DEVIL 4000
Gas Type	Propane
BTU Rating	400,000
Maximum Pressure	Bottle Pressure
Minimum Pressure	1.4 Bar
Regulator Output	20 PSIG (0.14MPa)
Electrical Input	220-240V, 50Hz
Ignition	Direct Spark
Primary Flame Control	Solid State 10-15 Sec timing
Operating Temperature Range	15 °C - 35 °C
Fuel Consumption	5.2-8.4 kg/hr
Fuel Orifice Port No	1
Fuel Orifice Port Size	2.35 mm
Heated Air Output	1400 CFM
Weight	24.6 kg
Dimensions (L x W x H)	994 x 404 x 621 mm

WIRING DIAGRAM

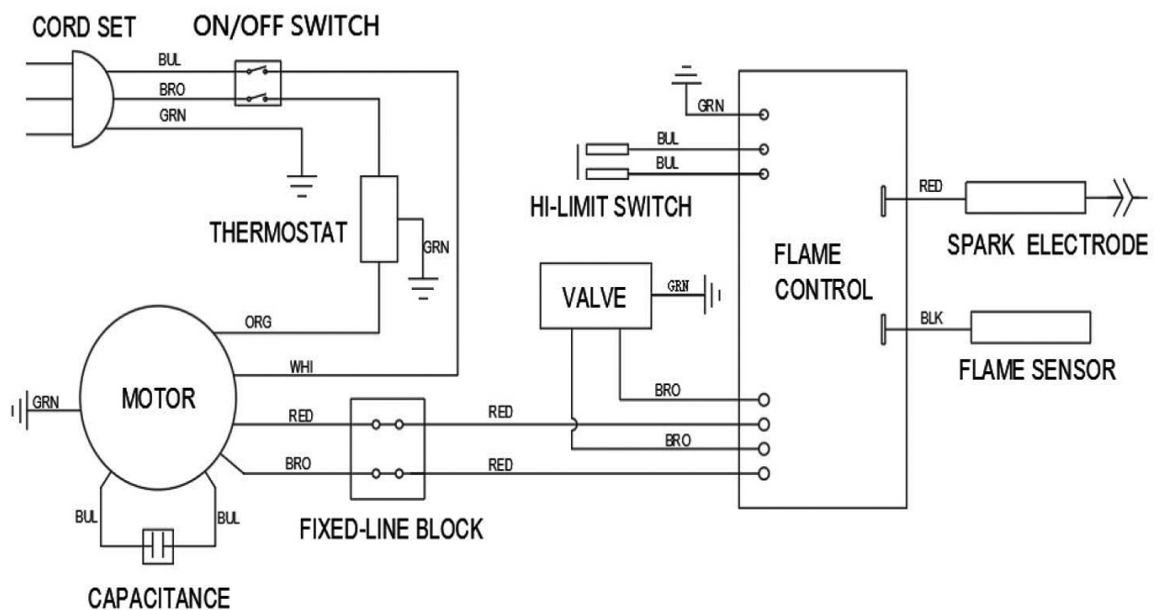

EXPLODED VIEW

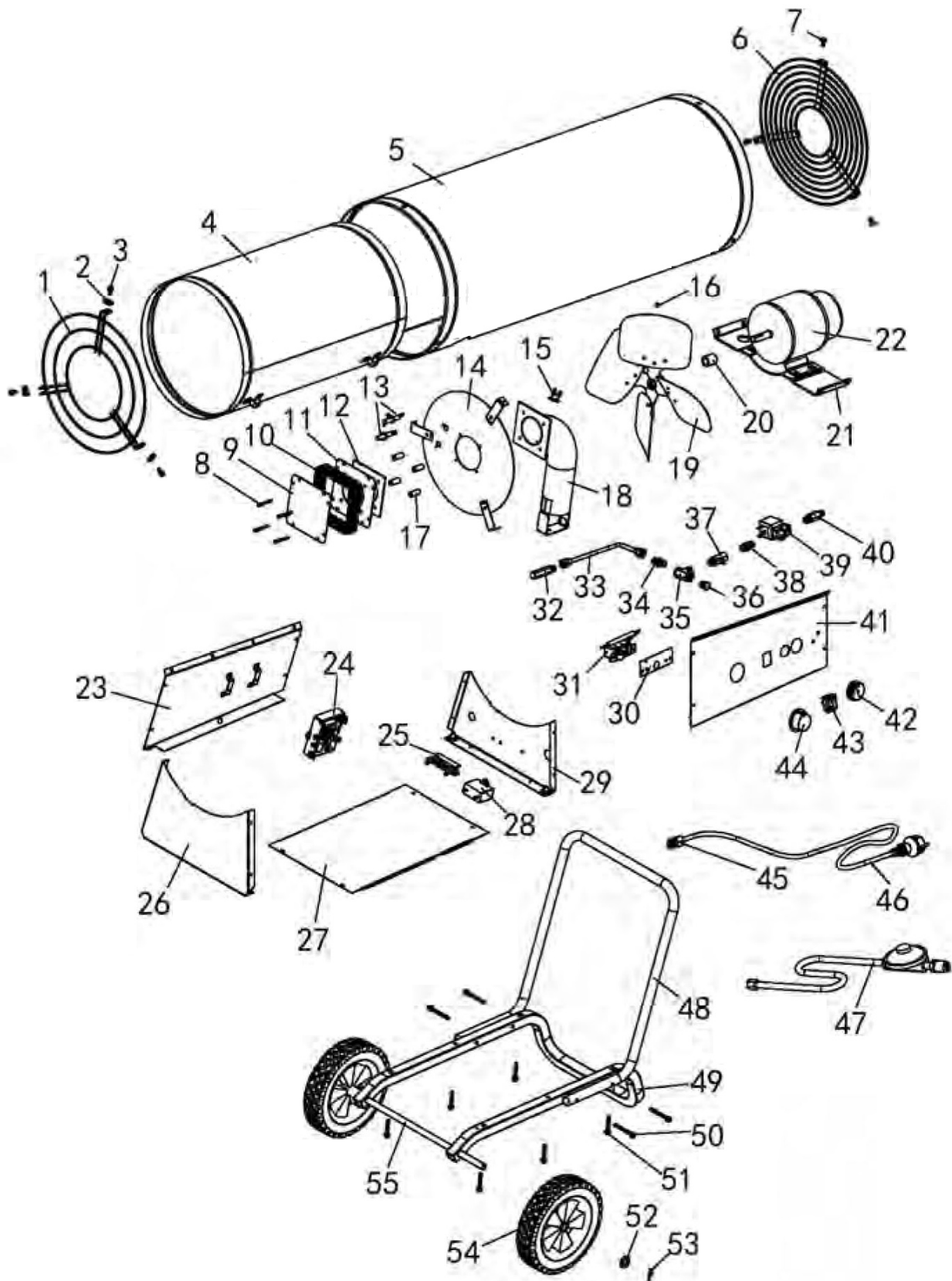

PARTS LIST

1	Front Guard
2	Locknut
3	Machine Screw
4	Middle Cylinder
5	Outer Shell
6	Grille Inlet
7	Machine Screw
8	Machine Screw
9	Burner Outer Plate
10	Burner Grids
11	Burner Inner Plate
12	Burner-Fibre Frax Gasket
13	Electrode-Flame Sensor
14	Flame Holder Assembly
15	High Limit Switch
16	Set Screw
17	Burner - SS Spacer
18	Burner-Mixing Tube
19	Fan
20	Fan Spacer-Nylon
21	Motor Mounting
22	Motor Assembly
23	Control Mounting Bracket
24	Flame Control
25	Terminal Board
26	Control Box End Panel
27	Control Box Bottom Panel
28	Capacitor

29	Control Box End Panel
30	Thermostat Mounting Bracket
31	Thermostat Assembly
32	Orifice (2.35 mm port)
33	Fuel Tube Assembly
34	Male Fitting, Conn. 1/4 MPT x 1/2
35	TEE 1/4 N PT, Female Fitting
36	Fitting, Plug 1/4 MPT
37	Burn Rate Adjustment Valve
38	Male Fitting Conn. 1/4 NPI x G1/4
39	Solenoid Valve
40	Inlet Connector
41	Control Box CRTL Panel
42	Burn Rate Adjustment Knob
43	Power Switch
44	Thermostat Knob
45	Strain Relief Bush
46	Power Cable Assembly
47	Hose/Regulator Assembly
48	Handle
49	Lower Frame
50	Machine Screw
51	Machine Screw
52	Spacer
53	Cotter Pin
54	Wheel
55	Axle

When requesting spare parts, please quote the reference GFDEV4000/01-55.

DECLARATION OF CONFORMITY

UK
CA

Clarke
INTERNATIONAL

Hennell Street, Epping, Essex CM16 4LG

DECLARATION OF CONFORMITY

This is an important document and should be retained.

We hereby declare that this product(s) complies with the following statutory requirement(s):

Electromagnetic Compatibility Regulations 2016
Electrical Equipment (Safety) Regulations 2016
Regulation 2016/426: Appliances Burning Gaseous Fuels.
The Restriction of the Use of Certain Hazardous Substances in Electrical and Electronic Equipment Regulations 2012

The following standards have been applied to the product(s):

EN 60335-2-102:2016, EN 60335-1:2012+A11:2014+A13:2017+A1:2019+A14:2019,
EN 62233:2008, EN 55014-1:2017+A11:2020, EN 55014-2:2015, EN 61000-3-2:2014,
EN 61000-3-3:2013, EN 1596:1998+A1:2004, IEC 62321-3-1:2013, IEC 62321-5:2013,
IEC 62321-4:2013, IEC 62321-7-2:2017, IEC 62321-7-1:2015, IEC 62321-6:2015, IEC 62321-8:2017.

The technical documentation required to demonstrate that the product(s) meet(s) the requirement(s) of the aforementioned legislation has been compiled and is available for inspection by the relevant enforcement authorities.

The UKCA mark was first applied in: 2022

Product Description: Gas Heaters
Model number(s): Little Devil II, DEVIL 700, 900, 1600, 2100, 4000 Series
Serial / batch Number: N/A
Date of Issue: 29/06/2022

Signed:

J.A. Clarke
Director

DEVIL 4000 UKCA Clarke DOC 062922

Page 1 of 1

CE

Clarke
INTERNATIONAL

Fitzwilliam Hall, Fitzwilliam Place, Dublin 2

DECLARATION OF CONFORMITY

This is an important document and should be retained.

We hereby declare that this product(s) complies with the following directive(s):

2014/35/EU Low Voltage Equipment Directive
2014/30/EC Electromagnetic Compatibility Directive.
2016/426/EU Appliances Burning Gaseous Fuels
2011/65/EU Restriction of Hazardous Substances.

The following standards have been applied to the product(s):

EN 60335-2-102:2016, EN 60335-1:2012+A11:2014+A13:2017+A1:2019+A14:2019,
EN 62233:2008, EN 55014-1:2017+A11:2020, EN 55014-2:2015, EN 61000-3-2:2014,
EN 61000-3-3:2013, EN 1596:1998+A1:2004, IEC 62321-3-1:2013, IEC 62321-5:2013,
IEC 62321-4:2013, IEC 62321-7-2:2017, IEC 62321-7-1:2015, IEC 62321-6:2015, IEC 62321-8:2017.

The technical documentation required to demonstrate that the product(s) meet(s) the requirement(s) of the aforementioned directive(s) has been compiled and is available for inspection by the relevant enforcement authorities.

The CE mark was first applied in: 2011

Product Description: Gas Heaters
Model number(s): Little Devil II, DEVIL 700, 900, 1600, 2100, 4000 Series
Serial / batch Number: N/A
Date of Issue: 29/06/2022

Signed:

J.A. Clarke
Director

DEVIL 4000 CE Clarke DOC 062922

Page 1 of 1

A SELECTION FROM THE VAST RANGE OF

Clarke®

QUALITY PRODUCTS



AIR COMPRESSORS
From DIY to industrial, Plus air tools, spray guns and accessories.

GENERATORS
Prime duty or emergency standby for business, home and leisure.

POWER WASHERS
Hot and cold, electric and engine driven - we have what you need

WELDERS
Mig, Arc, Tig and Spot. From DIY to auto/industrial.

METALWORKING
Drills, grinders and saws for DIY and professional use.

WOODWORKING
Saws, sanders, lathes, mortisers and dust extraction.

HYDRAULICS
Cranes, body repair kits, transmission jacks for all types of workshop use.

WATER PUMPS
Submersible, electric and engine driven for DIY, agriculture and industry.

POWERTOOLS
Angle grinders, cordless drill sets, saws and sanders.

STARTERS/CHARGERS
All sizes for car and commercial use.



PARTS & SERVICE: 0208 988 7400

Parts Enquiries
Parts@clarkeinternational.com

Servicing & Technical Enquiries
Service@clarkeinternational.com

SALES: UK 01992 565333 or Export 00 44 (0)1992 565335

Clarke® INTERNATIONAL Hemnall Street, Epping, Essex CM16 4LG
www.clarkeinternational.com